



VERTICAL PUMP USED FOR RAW SULFURIC ACID

CENTRIFUGAL AND CANTILEVER PUMPS

A Customer Oriented Approach

The market continues to reward the products made in Parma by Salvatore Robuschi and the service provided, especially in terms of service and quick delivery times for spare parts.

BY ALESSANDRO GOBBI

Key elements of Salvatore Robuschi's success, operating on the market for more than 80 years, are customer-oriented design and the expertise of its technical and sales staff.

The company's primary goal is in fact to become a reference name for process pumps, seeking to design "tailored" solutions for every need. One of the company's prerogatives is also a prompt service, fast deliveries and great flexibility in tackling immediate needs.

The series of centrifugal pumps by Salvatore Robuschi includes models with closed or open impellers complying with DIN 24256 - UNI EN 25199 (ex ISO 5199) - UNI EN 22858 (ex ISO 2858) standards, free flow pumps with VORTEX impellers, as well as channel and multi-stage impellers. All come in stainless steel and special alloys, except for the latter which is cast iron. The production programme also includes a light and less expensive series in AISI 316 with capacity up to 90 m³/h.

We asked Michele Robuschi, the company's General Manager, a few questions.

Which are your main fields?

There is no easy answer to that as we cover so many sectors: chemical and pharmaceutical industry, food processing industry in the form of washing and conveying units, evaporation/concentration processes, distilleries, oenology, wastewater and special waste treatment, pulp and paper, textile industry, butchering and farming, biogas production, desalination, boat factories, etc.

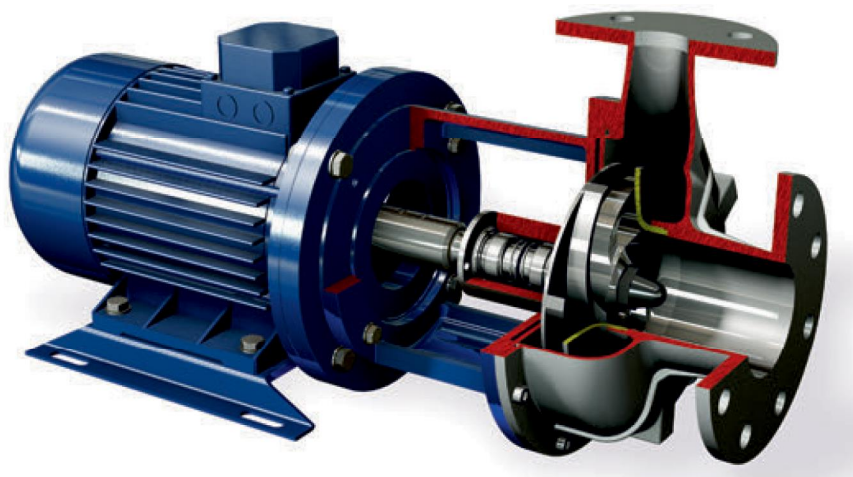

HG PUMP - SEMI OPEN IMPELLER - DOUBLE BACK TO BACK SEAL ARRANGEMENT

If we exclude the sectors where API pumps are used such as Oil & Gas, marine industry and clean water services, we cover almost all other sectors, clearly where centrifugal pumps are concerned. We also work with some engineering companies.

Which is the engineering philosophy behind your products?

Our goal from a construction point of view is to make standard those features that other manufacturers consider special. Obviously this implies the use of more complex components, but it brings speedy delivery, great application versatility, the possibility of transforming quickly and economically pumps to adapt them to new plant and production needs, and reduced maintenance costs. This means great operating savings. From a hydraulic standpoint, the range was designed to deliver a great number of models and therefore achieve maximum efficiency in every situation.

Closed microcasted impellers for clean liquids, semi-open impellers for liquids with solids, new concept multi-channel impellers for large capacities (today up to 2000 m³/h) of liquids containing also solid parts and free flow pumps with vortex impellers (new models with up to 200 mm spherical passage will be available soon). Great attention has also been placed on research to achieve very low NPSH values.

The company has also recently made important investments. Can you tell us something about them?

The market continues to appreciate our products and the relevant service, especially in terms of assistance and fast delivery times for spare parts. We have recently installed some new production lines. This involves also the expansion of



VERTICAL PUMP

COMPONENTS
AND INSTRUMENTS

SOME SIGNIFICANT SUPPLIES BY SALVATORE ROBUSCHI

Solution	Description
----------	-------------

Hot and dirty oil transfer

Cantilever pump: RCC 32 16A 4B22 100 3
 Performance: Flow 15 m³/h - head 9 m
 liquid: hot vegetal oil with chips particles
 (5 - 10 mm) - 180 °C



VERTICAL PUMP

Cantilever pumps can be used to collect dirty hot oil coming from industrial fryers: solids particles will be delivered to the filters without pump's clogging or mechanical seal failure. A key feature of cantilever pump is that there no bearings or bushings submerged therefore the pump can handle liquid with solids and operate dry.



Evaporator plant forced circulation

Pump: RGL 125 25C 2C15 C226
 Performance: Flow 160 m³/h - head 16 m - NPSH 1,2 m
 Liquid: salty waste water and crystals.
 Specific gravity 1,3.



RG PUMP - SEMI OPEN IMPELLER

The pumps work under vacuum. They circulate and extract concentrated liquid from the concentration tank where involatile elements are separated from a solution, obtaining deionized water and a "concentrate".
 HG pumps, thanks to special design of impeller, is able to work with very low NPSHr. Pumps are equipped with mechanical seal designed to work in high vacuum condition.



Ultrafiltration

Pump: RBB 250 35E 4C75 C181 3
 Performance: Flow 1000 m³/h - head 10 m
 Liquid: water with oil emulsions.



RB PUMP - MULTI-CHANNEL IMPELLER

Ultrafiltration (UF) can be used to purify and recover water in waste oil emulsions from metal working processes such as turning, milling, grinding, rolling and degreasing, to reduce costs for waste handling.



High viscosity chemical liquids mixed with powders

RCB 100-25A 4C22 C140 3
 Performance: Flow 151 m³/h - head 22 m
 Liquid: Viscosity 400 cP - s.g. 1,42



RC PUMP - VORTEX IMPELLER

RC vortex impeller is able to pump, and mix liquids and high concentration of powders without clogging problems. The pump sucks the powder from the feed hopper connected directly to the suction pipe. Back-to-back seal arrangement allows the seals to work always in contact with clean liquids. The pumped liquid is an high performance, alkali-free set accelerator for use in both wet and dry mix spraying processes.





TEST HALL IN SALVATORE ROBUSCHI

the staff, in fact we engaged new people in the technical, marketing and shipping departments: a sign that to grow our company invests first of all in human resources and in the professional capacity of its employees.

For which application is it suitable your abrasion resistant Cantilevers?

Our Cantilever pumps are designed to work for more than 40,000 hours without mechanical maintenance interventions, and this means working 5 years without costs and continuously, without interruption. The ATEX version, without sliding parts and the consequent friction, makes installation particularly simple in Ex classified areas.

Transfer of particularly demanding media, molten salt, molten sulphur, zinc, nickel baths, paints, cataphoresis, media up to 500°C, glues, water containing salt or metal shavings, recovery tanks with control levels: all these are critical applications where the cantilever pump becomes an ultimate, long lasting solution.

Do you also make maintenance of centrifugal pumps?

We believe that after-sale assistance is as fundamental for the customer as it is for us, in fact it enables us to better understand how pumps are used and to introduce improvements, which are often suggested by our customers. An important aspect of after-sale service is the spare parts service, we guarantee 24-72 hour delivery depending on the type: the most usual pieces such as seals, gaskets, shaft sleeves, shafts are immediately available; it takes a few days more for impellers or parts built according to specifications.

What is the added value of Salvatore Robuschi products?

It is obvious that reliability increase and the possibility of facing extreme situations without causing machine downtime and maintenance mean also great economic savings.

This is exactly our product policy, which has not changed for years: a machine must not only do what it was designed for, but also guarantee a wide safety margin.

The market wants energy efficiency and low operating costs: our response is not only the curve with higher efficiency, but also minimum

maintenance, be extremely sturdy to optimize the life of the seals, provide versatility in the choice of the latter enabling the user to install any conformation without making any changes, mount microcasted impellers on the whole process range, maintaining the same level of characteristics and efficiency for the entire life of the pump.

E-mail: com@salvatorerobuschi.com

Web site: www.salvatorerobuschi.com

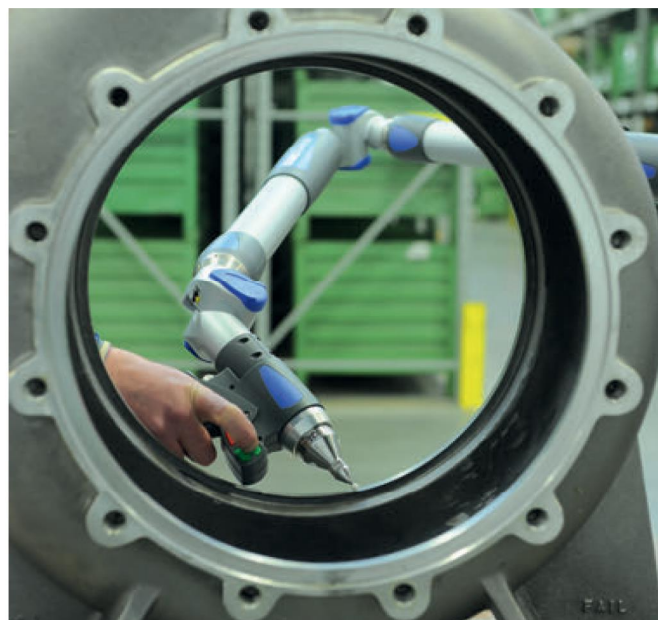

QUALITY CONTROL